

UCW-650VR SERIES CURTAIN WALL



THE WIT HOTEL - CHICAGO, IL

SYSTEM TECHNICAL DATA

- **UNITIZED**
- **THERMALLY - IMPROVED**
- **VERTICAL GASKET & HORIZONTAL CAPTURED**











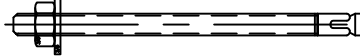

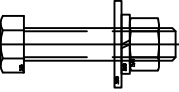

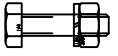
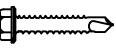
GLASS COMPANY



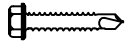

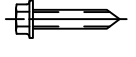
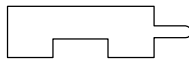









TABLE OF CONTENTS

- TEST REPORT
- FASTENER SCHEDULE
- GASKET PROFILE
- ALUMINUM EXTRUSION LIST
- ELEVATION & WALL SECTION DRAWING
- TYPICAL FRAMING DETAIL
- TYPICAL VENT FRAMING DETAIL
- TYPICAL TOP OF SLAB ANCHOR DETAIL
- 90° OUTSIDE CORNER MULLION DETAIL
- 90° OUTSIDE CORNER MULLION ANCHOR
- WINDOW WASHING TIE BACK DETAIL

FASTENER SCHEDULE

DESCRIPTION	PROFILE	DESCRIPTION	PROFILE
1/4" X 1 1/2" H.W.H. S.M.S. (AB POINT), CADMIUM PLATED, TYPICAL ASSEMBLY FASTENER		3/8" DIA. HILTI KWIK BOLT, 3 EMBEDMANT AS NOTED ON DETAIL ATTACHMENT OF STARTER SILL TO CURB	
1/4" X 1 1/2" P.F.H. S.M.S. (AB POINT), CADMIUM PLATED, ASSEMBLY FASTENER AT STACK JOINT		# 12 X 3/4" P.F.H. S.M.S. (AB POINT), CADMIUM PLATED, MISCELLANEOUS ATTACHMENT	
3/8"-16 X 1 1/2" H.H. BOLT, LC. WASHER AND NUT, STAINLESS STEEL, ANCHOR FIST AND TRANSFER LUG ATTACHMENT TO MULLION		# 14 X 1-1/2" P.F.H. S.M.S. (AB POINT), CADMIUM PLATED, MISCELLANEOUS ATTACHMENT	
1/4"-20 X 1" H.H. BOLT, LC WASHER AND NUT, CADMIUM PLATED, TIE-BACK ATTACHMENT TO MULLION		# 12-14 X 1-1/2" H.W.H. DRILL-FLEX, STALGARD FINISH, ANTI-LIFT FASTENER AND JAMB ATTACHMENT	
# 12-24 X 3/4" P.F.H. M.S., CADMIUM PLATED, ASSEMBLY FASTENER (GUTTER TO HEAD)			
# 12 X 1/2" P.F.H. S.M.S (AB POINT), STAINLESS STEEL, JAMB TRIM ATTACHMENT			
# 10-16 X 3/4" H.W.H. DRILL-FLEX, STALGARD FINISH, SHADOW BOW PANEL AND MISCELLANEOUS ATTACHMENTS			
# 12-14 X 2" H.W.H. DRILL-FLEX, STALGARD FINISH, ANTI-LIFT FASTENER AND JAMB ATTACHMENT			
# 10 X 1/2" P.F.H. S.M.S (AB POINT), STAINLESS STEEL, JAMB TRIM ATTACHMENT			
# 10 X 3/4" P.P.H. S.M.S (AB POINT), CADMIUM PLATED, MISCELLANEOUS ATTACHMENT			
# 12-14 X 1" H.W.H. S.M.S (AB POINT), CADMIUM PLATED, MISCELLANEOUS ATTACHMENT			
# 10 X 3/4" P.F.H. S.M.S. (AB POINT), CADMIUM PLATED, MISCELLANEOUS ATTACHMENT			

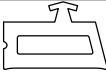

GASKET PROFILE LIST

DESCRIPTION	MFG. REF#	MANUFACTURER	PROFILE	DUROMETER
GUTTER SPACER ROD, RIGID PVC, X CONTINUOUS	TR-3564G	TREMCO		80 SHORE D DUROMETER
GUTTER HEAD	TR-4848E	TREMCO		45 + - 5 SHORE A DUROMETER CLOSED CELL EPDM SPONGE- BLACK
RAIN SCREEN, HORIZONTAL BLADE	TX-15667P	TREMCO		70 + - 5 SHORE A DUROMETER EPDM - BLACK
VERTICAL RAIN SCREEN BULB GASKET	TX-15669E	TREMCO		70 + - 5 SHORE A DUROMETER EPDM - BLACK
SETTING BLOCK AT GLASS (3/8" x 4")	TX-15084E	TREMCO		85 + - 5 SHORE A DUROMETER EPDM - BLACK
SETTING BLOCK AT GLASS (3/8" x 4")	TX-15820W	TREMCO		85 + - 5 SHORE A DUROMETER EPDM - BLACK
ISOLATOR AT GUTTER, RIGID PVC	TX-15090G	TREMCO		85 + - 5 SHORE D DUROMETER - BLACK
FACE CAP SNAP, RIGID PVC (12") LG. AT 12" O.C.	TX-15089G	TREMCO		80 SHORE D DUROMETER - BLACK
GUTTER SNAP RIGID PVC (2" LG.)	TR-2681G	TREMCO		80 SHORE D DUROMETER - BLACK
INTERIOR, FIXED, 1/4" GASKET	TR-15664W	TREMCO		70 + - 5 SHORE A DUROMETER EPDM - BLACK
EXTERIOR, WEDGE GASKET	TR-6329E	TREMCO		70 + - 5 SHORE A DUROMETER EPDM - BLACK
RAIN SCREEN BULB	TR-15075E	TREMCO		60 + - 5 SHORE A DUROMETER EPDM - BLACK
VERTICAL STACK GASKET	TR-15080E	TREMCO		50 + - 5 SHORE A DUROMETER EPDM - BLACK
VERTICAL STACK FINGER	TR-14532P	TREMCO		70 + - 5 SHORE A DUROMETER EPDM - BLACK
OPERABLE VENT, FINGER	TR-11884E	TREMCO		70 + - 5 SHORE A DUROMETER EPDM - BLACK
INTERIOR, FIXED, 5/16"	TR-15665W	TREMCO		70 + - 5 SHORE A DUROMETER EPDM - BLACK

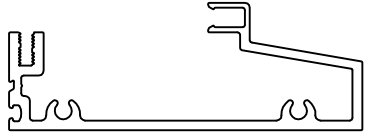
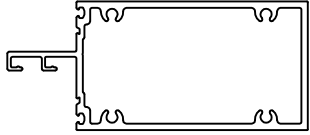
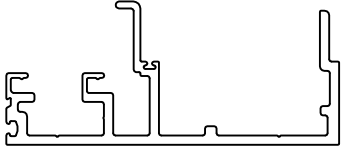
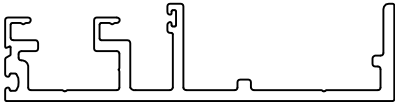
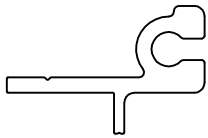
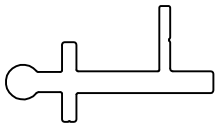
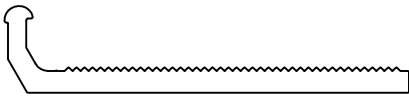
ALUMINUM EXTRUSION LIST

DIE No.	DESCRIPTION	MOMENTS OF INERTIA	WT./FT. (LBS.)	PERIMETER INCHES	PROFILE
TGF-369	HORIZONTAL GUTTER	X: 3.203 Y: 1.333	1.568	22.350	
TGF-374	INTERMEDIATE HORIZONTAL	X: 6.847 Y: 2.849	2.598	35.456	
TGF-377	MALE MULLION 4 1/2"	X: 2.953 Y: 1.229	1.650	23.372	
TGF-378	FEMALE MULLION 4 1/2"	X: 2.454 Y: 1.021	1.387	19.484	
TGF-381	TYPICAL ANCHOR SLIDE	X: .4250 Y: .1769	1.116	8.957	
TGF-382	TYPICAL ANCHOR	X: .037 Y: .375	0.994	8.054	
TGF-383	TOP OF SLAB ANCHOR	X: .207 Y: 14.119	3.726	18.626	

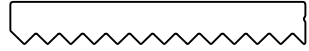
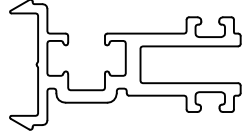
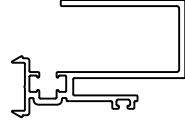
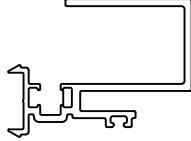
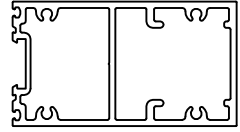

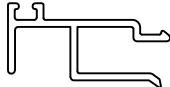
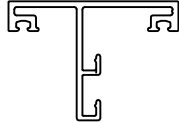
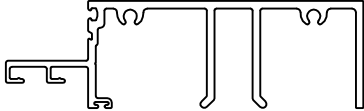
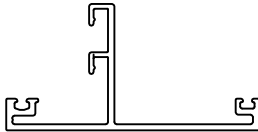
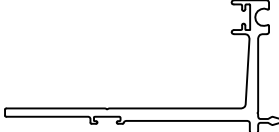
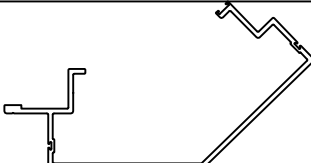

ALUMINUM EXTRUSION LIST

DIE No.	DESCRIPTION	MOMENTS OF INERTIA	WT./FT. (LBS.)	PERIMETER INCHES	PROFILE
TGF-384	SERRATED WASHER	X: .002 Y: .097	0.458	4.548	
TGF-418	VERTICAL FACE CAP, SNAP IN	X: .015 Y: .070	0.403	9.180	
TGF-419	FACE CAP, JAMB 1 $\frac{5}{16}$ "	X: .138 Y: .435	0.794	16.467	
TGF-420	FACE CAP, JAMB	X: .110 Y: .344	0.718	14.971	
TGF-421	MULLION JAMB	X: 2.414 Y: 5.556	2.989	38.397	
TGF-422	LUG, LIFT/ALIGN, JAMB	X: .011 Y: .089	0.607	4.436	
TGF-423	LUG, LIFT/ALIGN	X: .002 Y: .067	0.443	3.432	

ALUMINUM EXTRUSION LIST

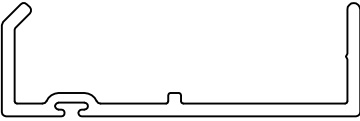
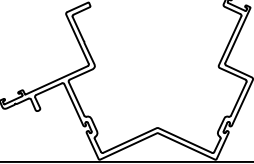
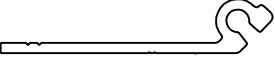
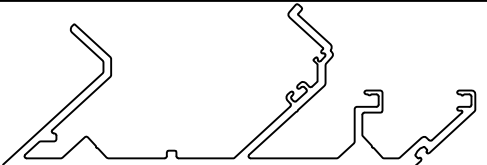
DIE NO.	DESCRIPTION	MOMENTS OF INERTIA	WT./FT. (LBS.)	PERIMETER INCHES	PROFILE
TGF-424	VERTICAL FACE CAP	X: .003 Y: .222	0.386	8.564	
TGF-425	ADAPTER, VENT	X: .009 Y: .044	0.269	7.194	
TGF-426	INTERMEDIATE HORIZONTAL, FACE CAP	X: .158 Y: .306	0.007	13.803	
TGF-427	HORIZONTAL STACK JOINT	X: .517 Y: 4.972	2.092	29.582	
TGF-428	HORIZONTAL STACK FACE CAP	X: .168 Y: .678	0.766	15.555	
TGF-429	GUTTER	X: .214 Y: 1.436	1.186	14.528	
TGF-430	CLOSER O.S.C.	X: 3.976 Y: 22.514	3.064	38.186	

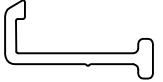
ALUMINUM EXTRUSION LIST

DIE NO.	DESCRIPTION	MOMENTS OF INERTIA	WT./FT. (LBS.)	PERIMETER INCHES	PROFILE
TGF-431	CLOSURE, END CAP	X: .021 Y: .359	0.479	8.876	
TGF-432	CLOSURE, I.S.C.	X: .911 Y: 2.680	1.408	25.464	
TGF-433	ANCHOR SLIDE, O.S.C.	X: .058 Y: 2.748	1.489	12.618	
TGF-434	MALE MULLION, 85° O.S.C.	X: 1.031 Y: 11.147	2.802	34.664	
TGF-435	LUG, LIFT/ALIGN, 85° O.S.C.	X: .013 Y: .184	0.707	5.132	
TGF-436	ANTI-BUCKLING CLIP, STRAIGHT	X: .001 Y: .012	0.128	2.979	
TGF-437	VERTICAL FACE CAP, 85° O.S.C.	X: .020 Y: 1.039	0.688	14.022	

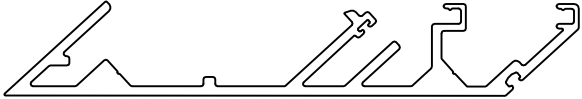
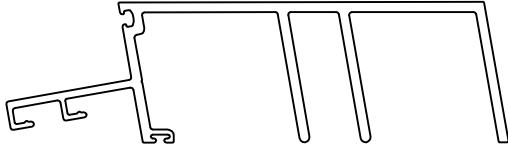
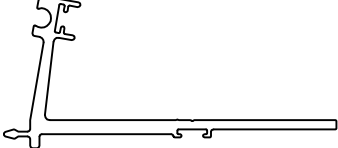
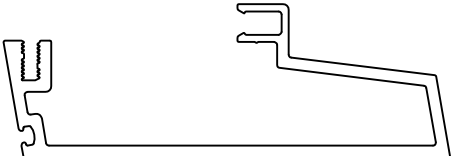
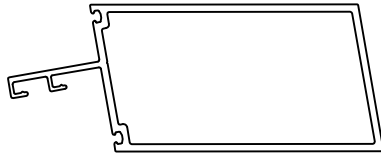
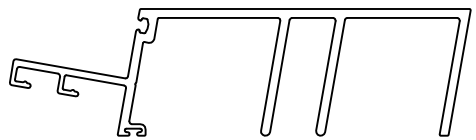
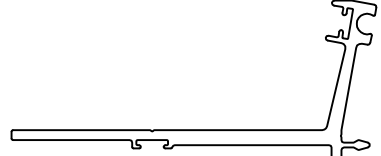

ALUMINUM EXTRUSION LIST

DIE No.	DESCRIPTION	MOMENTS OF INERTIA	WT./FT. (LBS.)	PERIMETER INCHES	PROFILE
TGF-438	FEMALE MULLION, 85° O.S.C.	X: .216 Y: 9.951	2.413	28.995	
TGF-440	HORIZONTAL STACK, OUTWARD	X: .524 Y: 5.091	1.979	28.578	
TGF-441	GUTTER, OUTWARD	X: .237 Y: 1.598	1.228	15.114	
TGF-442	HORIZONTAL GUTTER, OUTWARD	X: .302 Y: 3.171	1.526	21.441	
TGF-443	INTERMEDIATE HORIZONTAL, OUTWARD	X: 1.865 Y: 6.977	2.358	33.005	
TGF-444	HORIZONTAL STACK, INWARD	X: .467 Y: 5.328	1.986	28.570	
TGF-445	GUTTER, INWARD	X: .207 Y: 1.919	1.249	15.211	

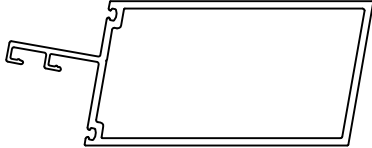
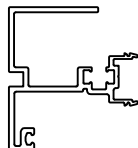
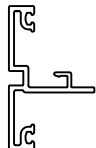
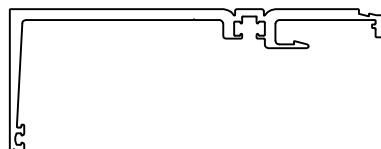
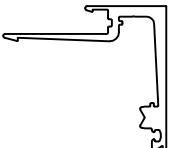
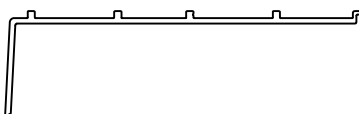
ALUMINUM EXTRUSION LIST

DIE No.	DESCRIPTION	MOMENTS OF INERTIA	WT./FT. (LBS.)	PERIMETER INCHES	PROFILE
TGF-446	HORIZONTAL GUTTER, INWARD	X: .297 Y: 3.168	1.480	20.790	
TGF-447	HORIZONTAL INTERMEDIATE, INWARD	X: 1.900 Y: 6.894	2.358	33.028	
TGF-449	FACE CAP, JAMB	X: .347 Y: .443	0.932	18.520	
TGF-450	FACE CAP, VERTICAL	X: .075 Y: .300	0.656	12.741	
TGF-451	HEAD RECEPTOR, EXTERIOR	X: .475 Y: 8.081	2.167	22.972	
TGF-452	HEAD RECEPTOR, TRIM	X: .289 Y: .669	1.115	13.677	
TGF-453	HEAD RECEPTOR, SPLICE SLEEVE	X: .092 Y: 3.148	0.952	16.753	

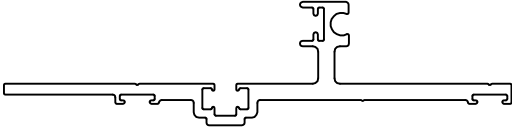
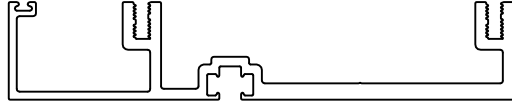
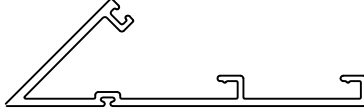
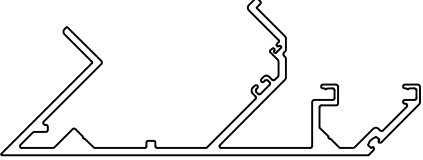
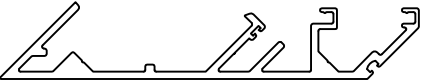
ALUMINUM EXTRUSION LIST

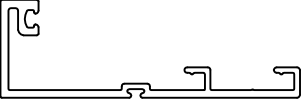
DIE No.	DESCRIPTION	MOMENTS OF INERTIA	WT./FT. (LBS.)	PERIMETER INCHES	PROFILE
TGF-454	GUTTER, STRIP	X: .099 Y: 2.606	1.483	18.452	
TGF-455	HORIZONTAL SILL, STRIP	X: .173 Y: 5.263	1.805	24.252	
TGF-524	90 ° O.S.C FACE CAP	X: .020 Y: 1.038	0.688	14.022	
TGF-525	90 ° O.S.C MALE MULLION	X: 1.031 Y: 11.147	2.802	34.664	
TGF-526	90 ° O.S.C FEMALE MULLION	X: 1.031 Y: 11.147	2.802	34.664	
TGF-527	90 ° O.S.C LUG, LIFT/ALIGN	X: .012 Y: .156	0.670	4.881	
TGF-528	INTERMEDIATE FACE CAP	X: .050 Y: .766	0.652	13.069	

ELEVATION & WALL SECTION DRAWING

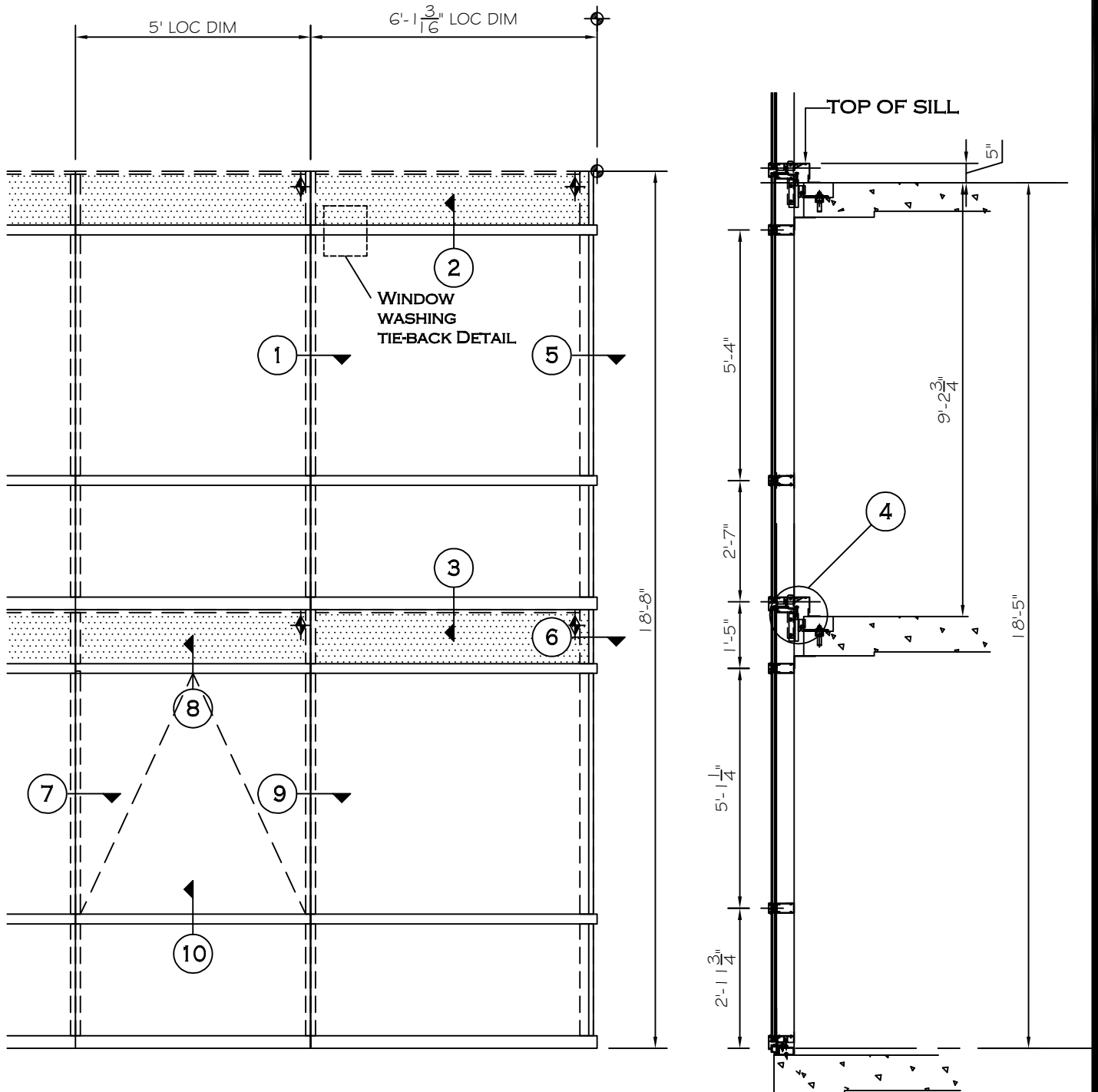

(A) ELEVATION
SYSTEM: UCW-650 VR

TYPICAL FRAMING DETAILS

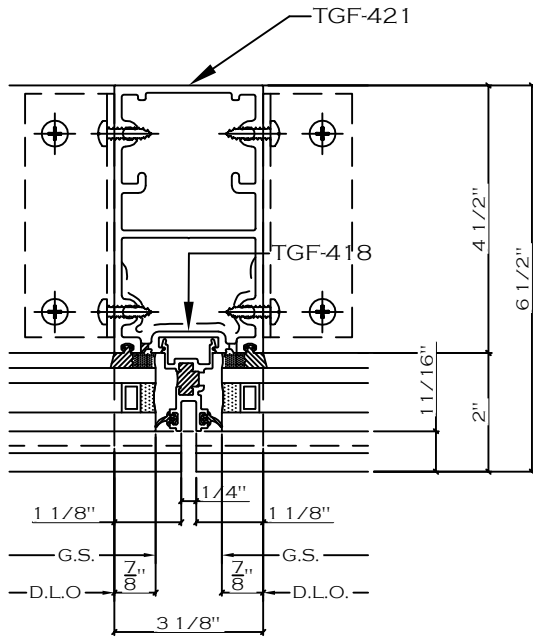

1 BUTT GLAZED MULLION @ VISION GL.
SYSTEM: UCW-650 VR

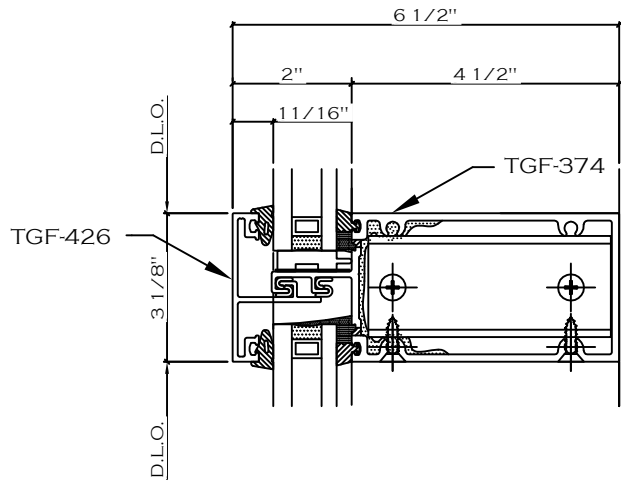

2 INTER. HORIZ. @ VISION GL.
SYSTEM: UCW-650 VR

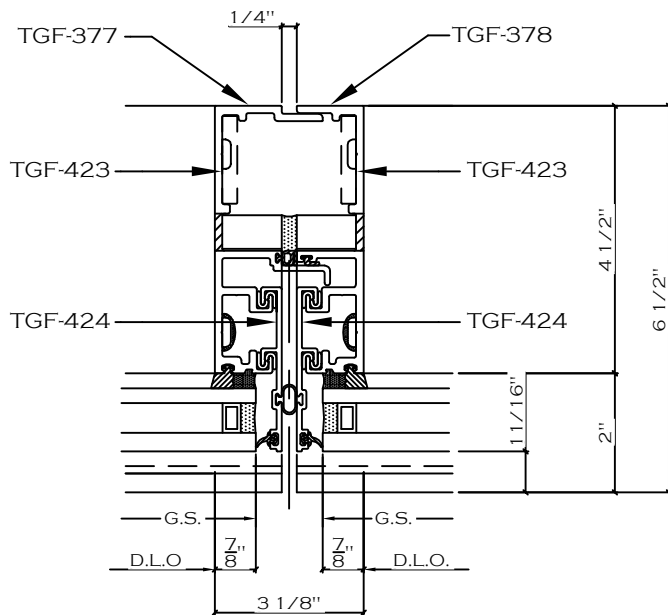

TYP. MULL @ VISION GL.
SYSTEM: UCW-650 VR

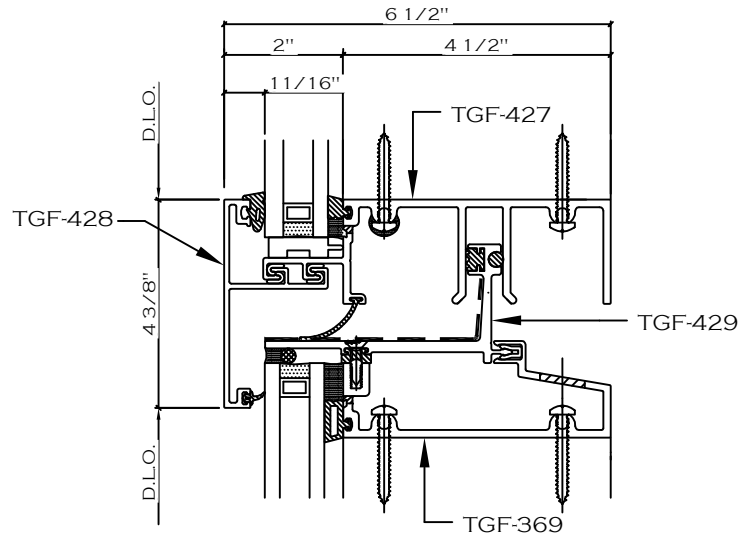

3 INTERM. STACK @ VISION GL.
SYSTEM: UCW-650 VR

TYPICAL TOP OF SLAB ANCHOR DETAIL

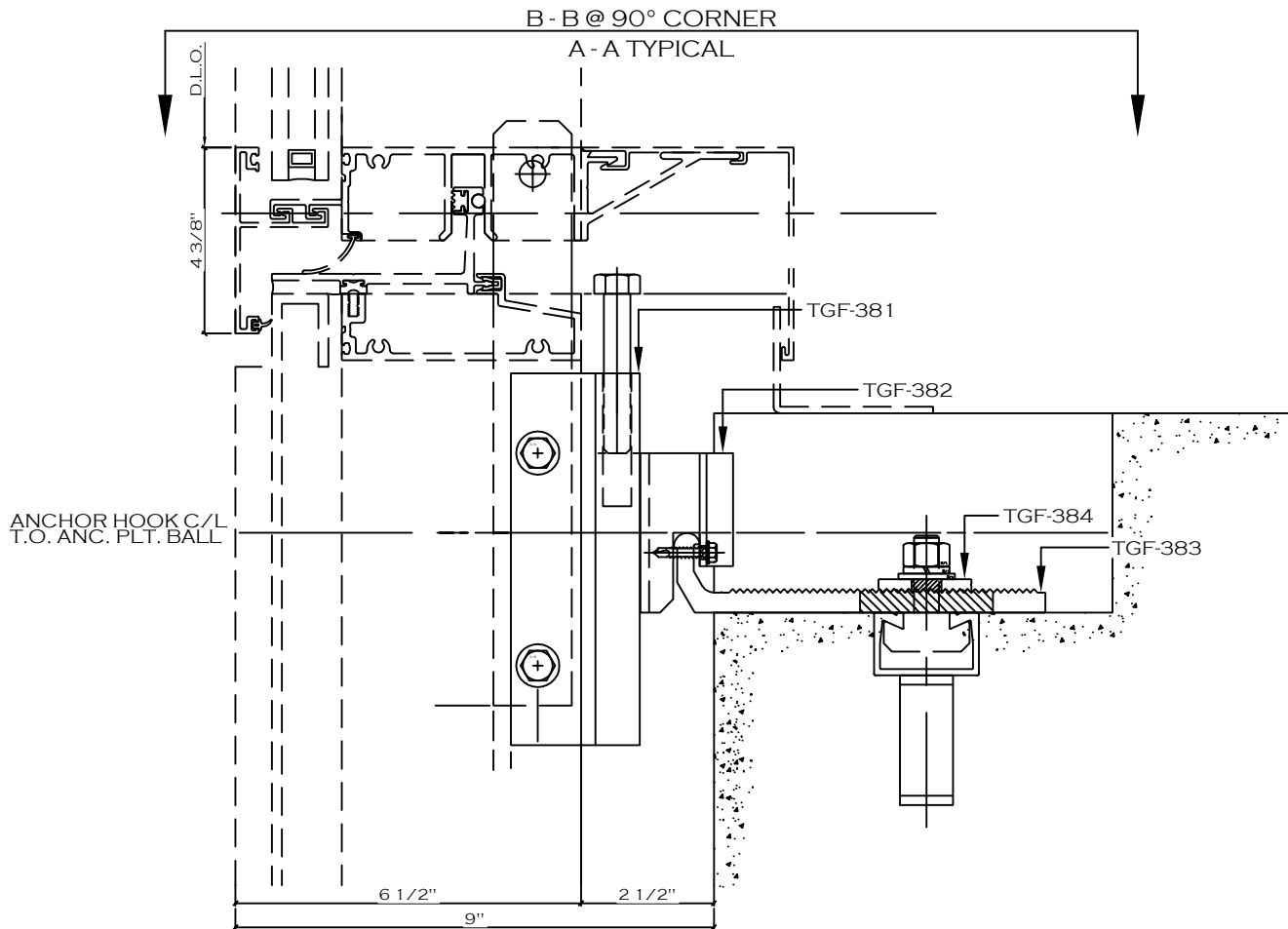
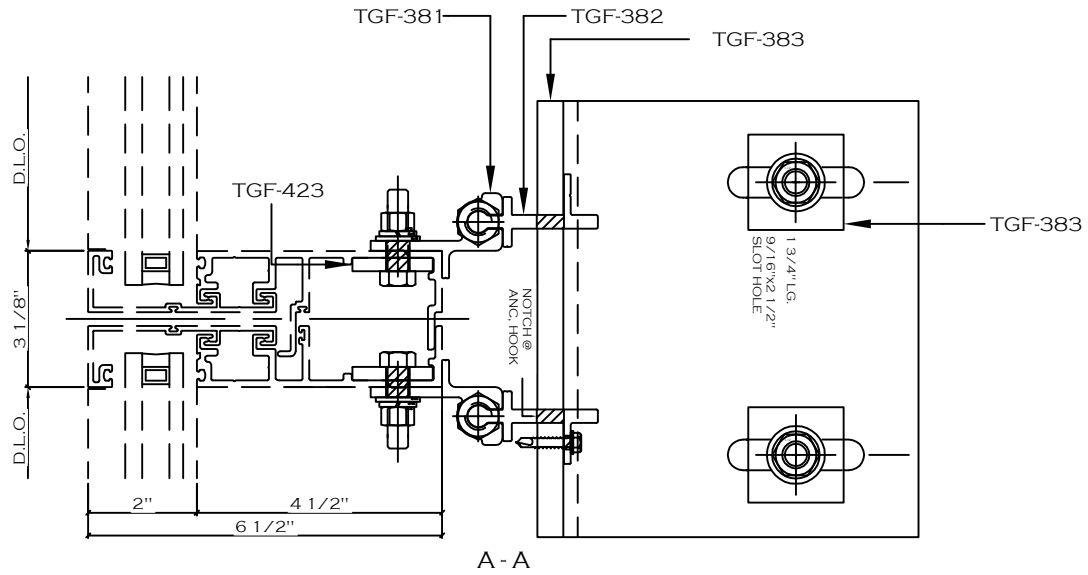

90° OUTSIDE CORNER MULLION DETAIL

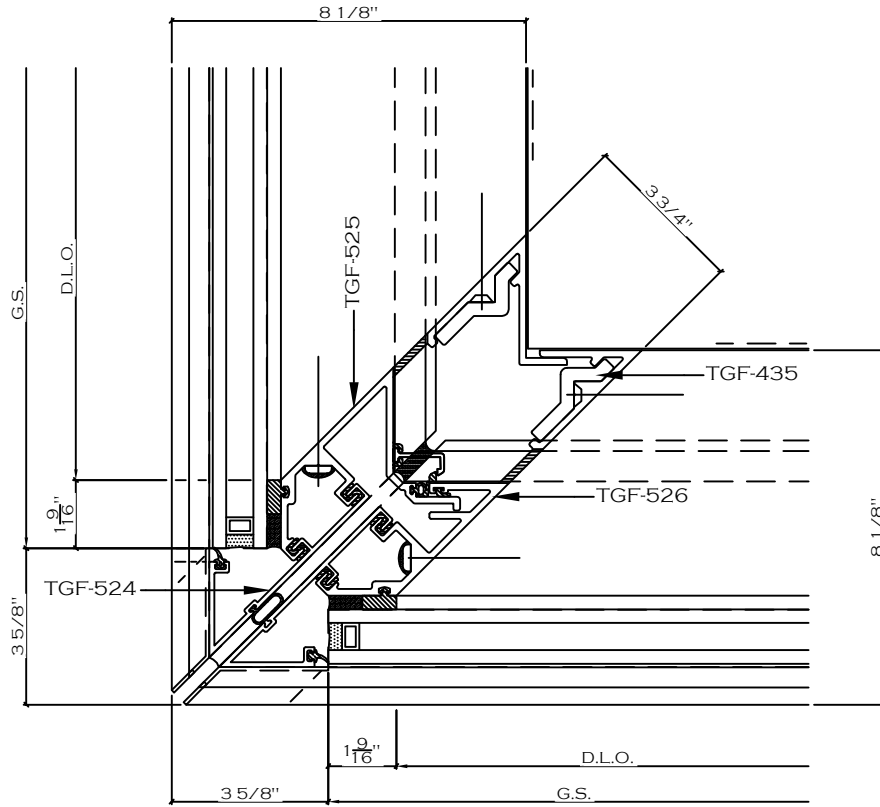

5 90° O.S. CORNER @ VISION
SYSTEM: UCW-650 VR

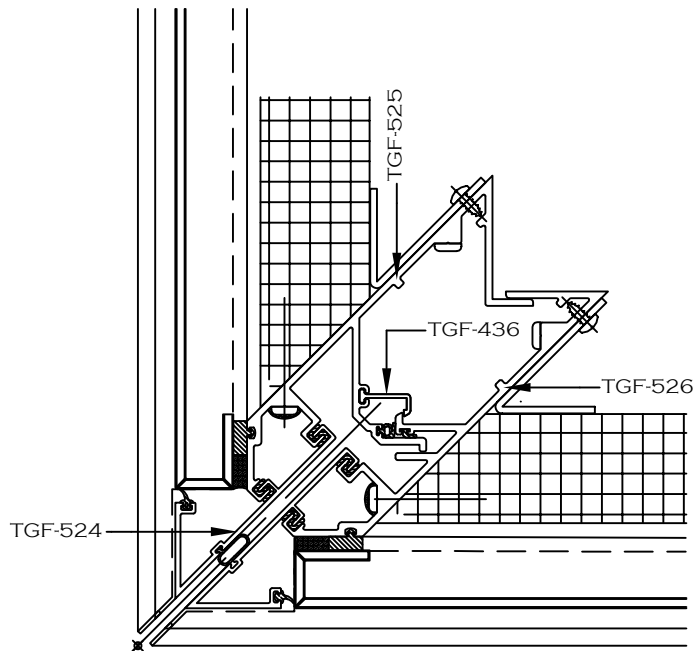

6 90° O.S. CORNER @ SPANDREL
SYSTEM: UCW-650 VR

90° OUTSIDE CORNER MULLION ANCHOR DETAIL

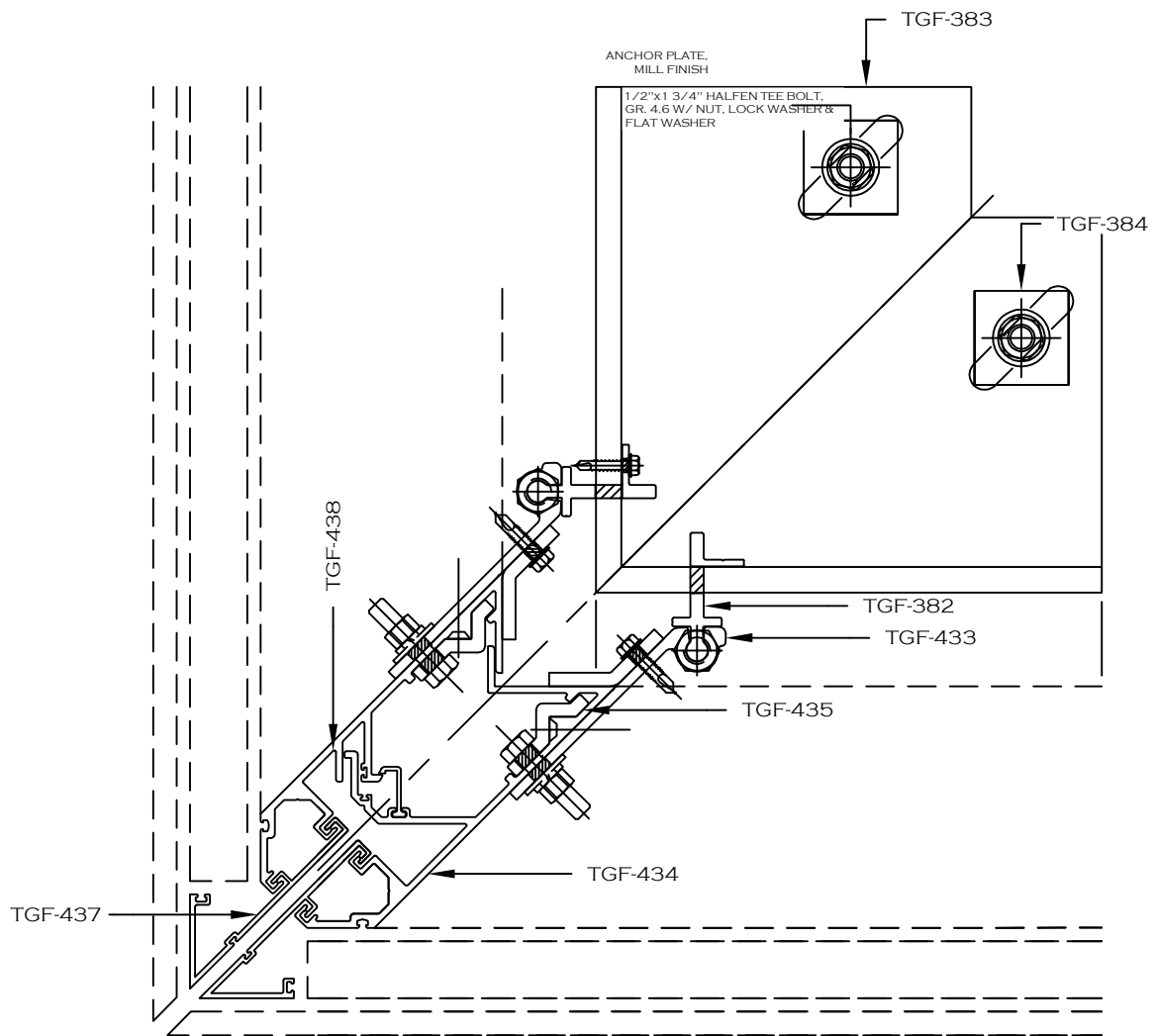

B - B

CORNER MULL ANCHOR PLAN
SYSTEM: UCW-650 VR

TYPICAL VENT FRAMING DETAILS

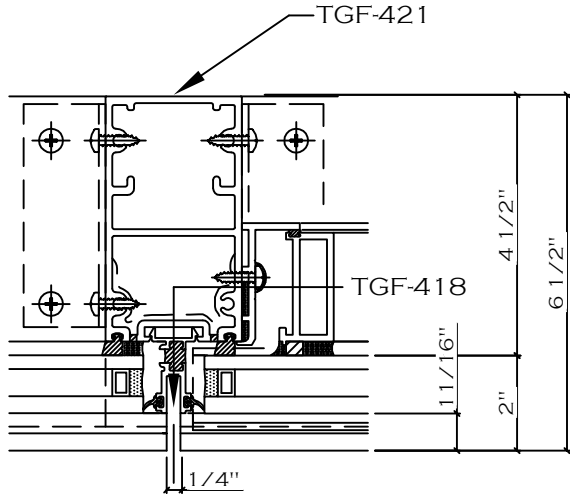

7 BUTT GLAZED MULLION @ VISION/VENT SYSTEM: UCW-650 VR

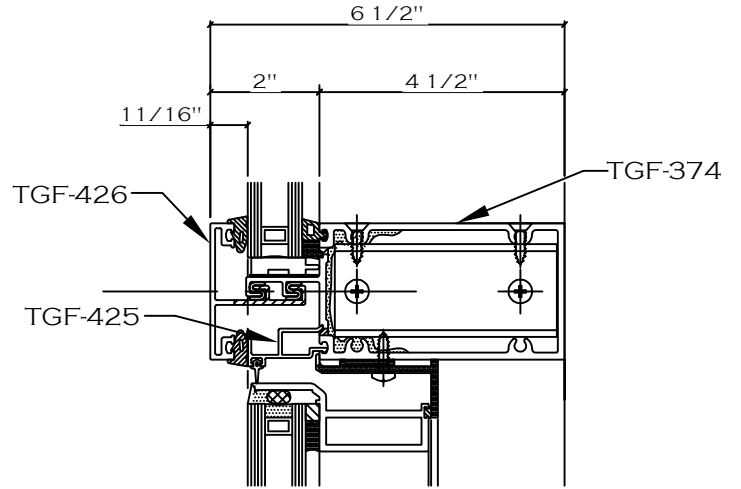

8 INTER. HORIZ. @ SPANDREL/VENT SYSTEM: UCW-650 VR

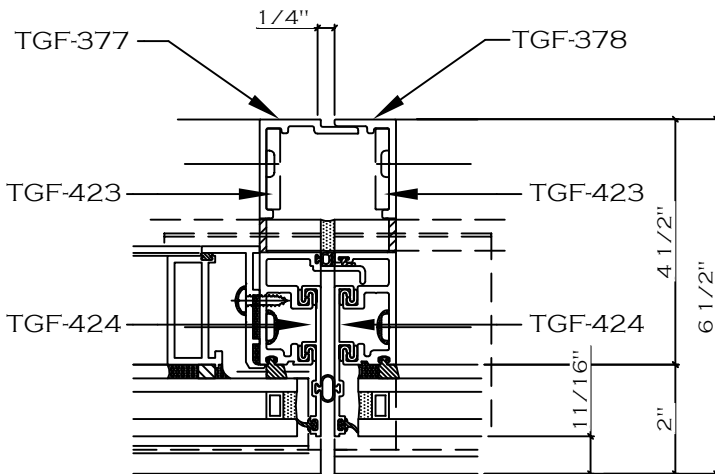

9 TYP. MULLION @ VISION GL./VENT SYSTEM: UCW-650 VR

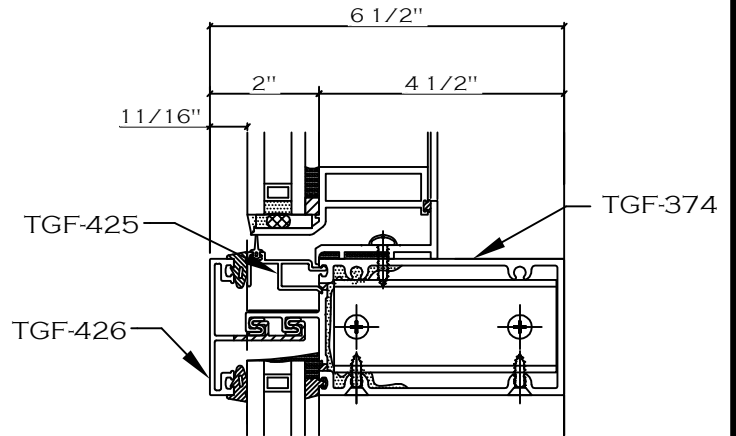

10 INTER. HORIZ. @ VISION GL./VENT SYSTEM: UCW-650 VR

WINDOW WASHING TIE-BACK DETAIL

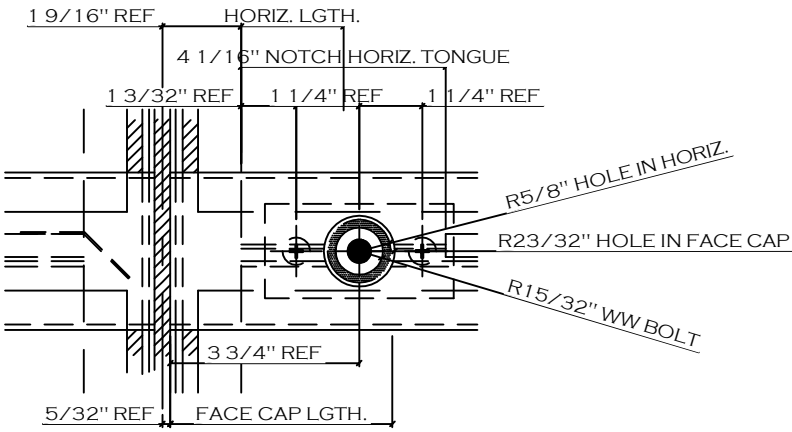

W.W. BOLT

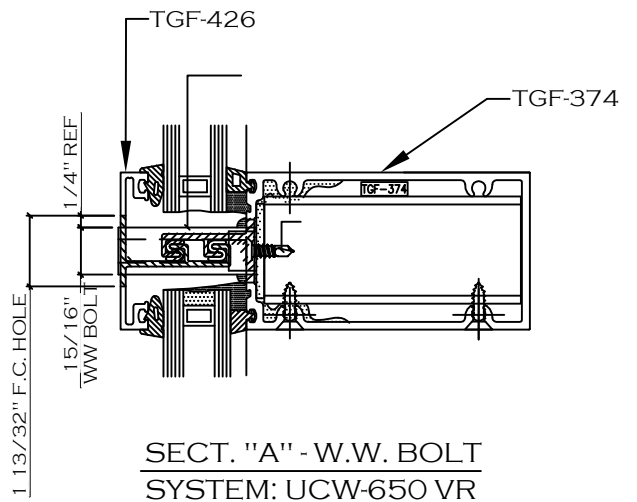

SECT. "A" - W.W. BOLT SYSTEM: UCW-650 VR

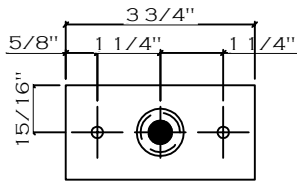

W.W. BOLT - FRONT
 MATERIAL: STAINLESS STEEL

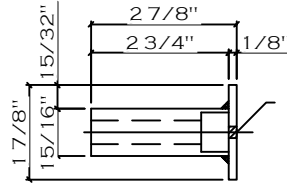

W.W. BOLT - SIDE